

Use Manual for Ceramic Hard Seal Wireless Auto Shut-off Valve

0WRX.466.762

1. Product overview

1.1 Main purpose and application range

Water pipes such as solar water heaters, faucets, and domestic water dispensers installed in homes are prone to water leakage when the water pressure is too high or the connections are aging and loose. Regardless of the severity of the situation, water leak is an annoying problem. This product is independently researched and developed by our company and is mainly used for water leakage protection in household, commercial and industrial water supply and drainage systems.

The ceramic hard seal wireless auto shut-off valve is composed of a ceramic core electronic ball valve, a wireless receiving controller and a wireless water immersion detector. The principle is that the wireless water immersion detector is installed in a place where is most easily contact water when leakage happens, when the water immersion probes of the detector are in contact with water, it will change the resistance between the probes and quickly close the electronic ball valve to cut off the water source.

1.2 Product features

- Wireless water immersion detector, the signal adopts wireless transmission. Multi-point water leakage monitoring, long sensing distance.
- The wireless water immersion detector has low power consumption, and it is convenient to replace the battery.
- The main control valve adopts light torque ceramic core ball valve, which has small flow resistance and large flow rate.
- The main control valve has a built-in large-capacity rechargeable lithium battery, which can be used for emergency use in the event of a power failure.
- The waterproof design of the wireless water immersion detector prevents corrosion of internal circuit.

1.3 Working principle

Using special ceramic materials with high hardness (\geq HRA85) and corrosion resistance, a pair of sphere and platelike part with through holes are made. The sphere is processed into high-precision concave-convex spherical surface and fits with the platelike part, and rotated relative to 90° , thereby to achieve the opening and closing effect of fluid or gas.

Due to the high hardness and density of the material, the bonding surface of the two parts is very narrow (1~3 mm), the opening and closing torque is very small, which provides a good precondition for automatic control of opening and closing.

It is a pioneering work for using this technology in the auto shut-off valve products in the residential water treatment system due to its rationality, economy, and advancement.

1.4 Product structure and technical parameters

• Product size

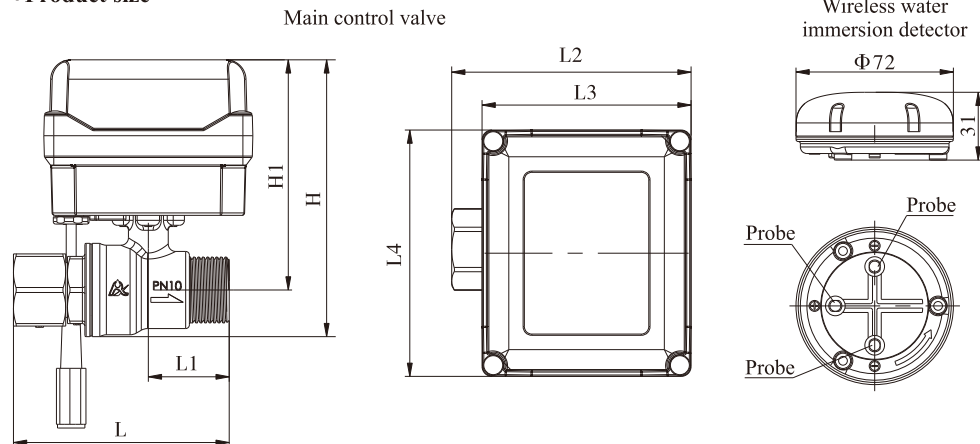

Model No.	L	L1	L2	L3	L4	H	H1	NPS
F104E	86.7	32.5	96.2	84	99	111.5	92.5	G3/4
F104G	103	55	90	84	99	125.5	102.5	G1

• Product structure composition

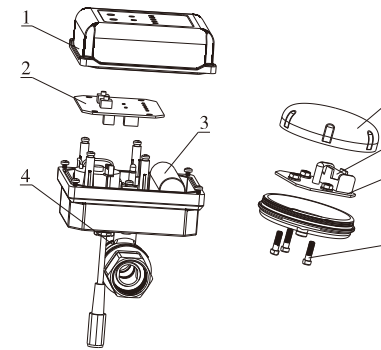

No.	Part Name
1	Dust cover for main control valve
2	Control board for main control valve
3	Rechargeable lithium battery
4	Ceramic core electric ball valve assembly
5	Stainless steel probe
6	Wireless water immersion circuit board
7	Alkaline dry battery
8	Top cover for wireless water immersion detector

• Technical parameter

Model No.	Name	Power adapter input	Power adapter output	Built-in battery parameters	Environment temperature	NPS
F104E	Main control valve	100~240VAC	DC12V	2500mAh/7.4V Rechargeable lithium battery	5~50℃	G3/4
F104F	Wireless water immersion detector	/	/	12V/ 23A Alkaline dry battery	5~50℃	/
F104G	Main control valve	100~240VAC	DC12V	2500mAh/7.4V Rechargeable lithium battery	5~50℃	G1

Remarks: There is 1 piece of wireless water immersion detector as the standard configuration. If you want to get more, you need to purchase it separately.

2. Product installation and operation

2.1 Product Installation

A. Installation of the main control valve

Before installation, please read this user manual carefully, and prepare all the materials and tools required for installation to ensure the normal use of the product after installation.

During installation, connect the electronic ball valve to the pipeline that needs to be cut off when leakage occurs, and install it in the direction of water flow indicated by the arrow on the ball valve.

B. Installation of wireless detector

① The wireless water immersion detector relies on the conduction of the electrode to determine whether there is water leakage. When installing it, please place it in a low-lying place where water may accumulate when water leaks.

② The wireless water immersion detector needs to be installed in the effective sensing area. When the installation location is selected, short-circuit the positive and negative poles of the probe on the detector, and check whether there is a leak alarm on the main control valve to confirm whether the installation location can effectively sense.

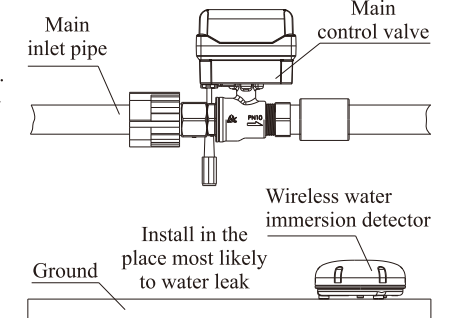

C.Schematic diagram after installation

Note: The main control valve cannot be installed in a confined space where the signal is isolated, such as thicker load-bearing walls, metal confined spaces, and places with magnetic interference. The above spaces will cause the main control valve and wireless water immersion detector to fail to communicate. Please test the induction before installation!

2.2 Operation

A.Interface display

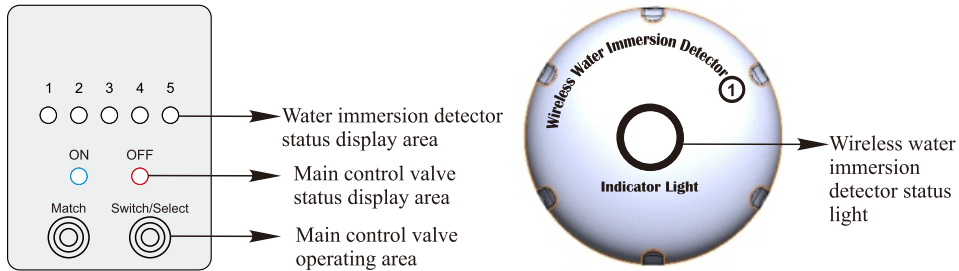

B.Product pairing

The standard wireless detector has been paired with the main control valve by default before leaving the factory. Before installation, please test whether the pairing of the wireless detector and the main control valve is valid (Operation method: The probe of the wireless water immersion detector is placed in the water, and there should be water between the probes. Check whether the main control valve has an alarm. If there is an alarm and the corresponding indicator light is flashing (for example, No. 1), it means that the pairing is valid. If there is no alarm and the corresponding indicator light is not flashing, please re-pair.)

Pairing method:

Press and hold the button on the main control valve for more than 3 seconds, at this time the No. 1 light in the indicator light flashes, then short press , after selecting the corresponding indicator light position, connect any positive and negative poles of the wireless water immersion probe, the indicator light of the wireless water immersion detector flashes, you will hear a sound "Di" from the main control valve, and the indicator light is always on, indicating that the pairing is successful. After success, you can test the display status of the main control valve after the positive and negative poles are shorted. If there is the alarm, the pairing is normal. The main control valve supports 5 wireless detectors to access the network.

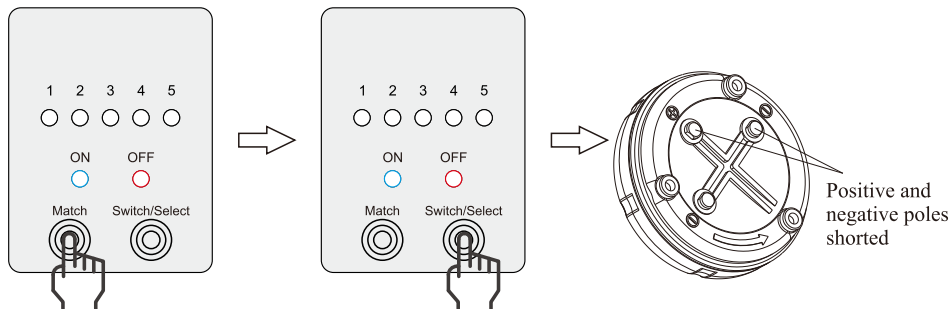

Long press the "Match Button", the indicator light flashes

Short press "Switch/Select", the corresponding number indicator light flashes

Short-circuit the positive and negative poles of the detector, you will hear a sound "Di", and the pairing is successful.

C.Release the water leakage state

When water leaks, the water on the ground overflows the probe of the wireless water immersion detector, the indicator light of the wireless detector will flash for a maximum of 10 seconds. At the same time, after the main control valve receives the signal, it will quickly switch the ball valve to the closed state and turn off the water source. At this time, the detector light corresponding to the main control valve flashes quickly, the buzzer continues to alarm, and the red indicator light "OFF" of the main control ball valve is always on.

Release: Clean the wireless detector, wipe off the water on the probe, long press the button, the main control valve is switched to the open state, at this time, the green light "ON" of the ball valve is turned on and the buzzer alarm is released.

Remarks: Under normal conditions of use, short press the button to switch the main control valve on/off state.

3.Battery life reminder and replacement

3.1 Main control valve battery: The main control valve has a built-in pair of rechargeable lithium batteries, which can last for 24-48 hours and it can be turned on and off 5 times, when the main control valve is fully charged during a power outage; The life of the battery is about 3 years, when using for a long time, please pay attention to replacing the battery to prevent the battery from being unable to be recharged and causing a power failure and it cannot be automatically turned off.

Replace the battery

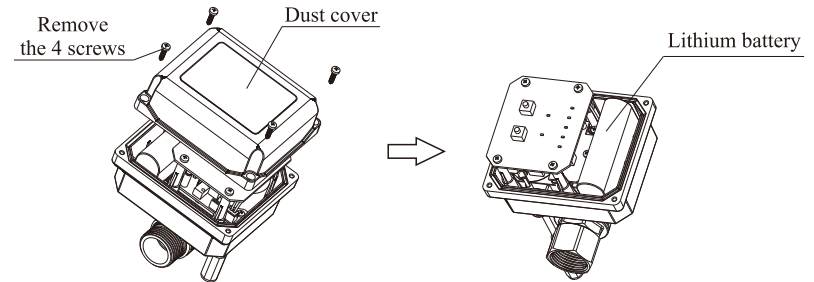

Remove the 4 screws on the dust cover, remove the old lithium battery, replace it with a new one, and insert the plug.

3.2 Wireless detector battery: The new battery of the wireless water immersion detector is normally valid for 3 years (ps: It emits 32 pulses when in use). When the wireless detector battery is insufficient, the indicator light of the corresponding number of the main control valve and the "OFF" indicator light flash together, and the buzzer alarms at the same time. It indicates that the battery on the wireless water immersion detector needs to be replaced. After the battery is replaced, the flashing indicator light and the buzzer alarm sound should be released.

4.Warranty Card

Dear client:

This warranty card is the guarantee proof of our products. It is kept by client self. You could get the after-sales services from the supplier. Please keep it properly. It couldn't be retrieved if lost. It couldn't be repaired free of charge under the below conditions:

1. Guarantee period expired. (One year from the manufacturing date);
2. Damage resulting from using, maintenance, and keeping that are not in accordance with the instruction;
3. Damage resulting from repairing not by the appointed maintenance personnel;
4. Content in guarantee proof is unconfirmed with the label on the real good or be altered;
5. Damage resulting from force majeure.

Product Name	Ceramic Hard Seal Wireless Auto Shut-off Valve		
Model		Code of Valve Body	
Purchase Company Name		Tel/Cel.	
Problem			
Solution			
Date of Repairing	Maintenance Man Signature		Date of Accomplishment

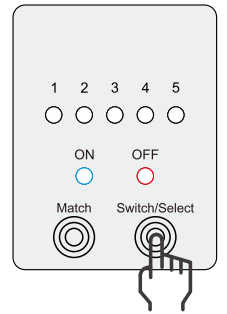

Long press the "Switch/Select" button, the main control valve is switched to the open state.

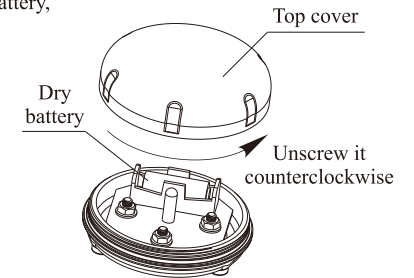

Replace the battery